

GS 04

Forked photoelectric sensors

en 04-2016/04 50110846



20/30/50/80/120/220mm



- Sensitivity adjustment and light/dark switching for optimal adaptation to the application
- Sensitivity adjustment on the back of the fork
- Robust metal housing and glass optics for protection against environmental influences
- Transmitter and receiver are installed in the same housing, therefore easy and fast mounting (excessive mounting brackets and extensive alignment not necessary)

Dimensioned drawing

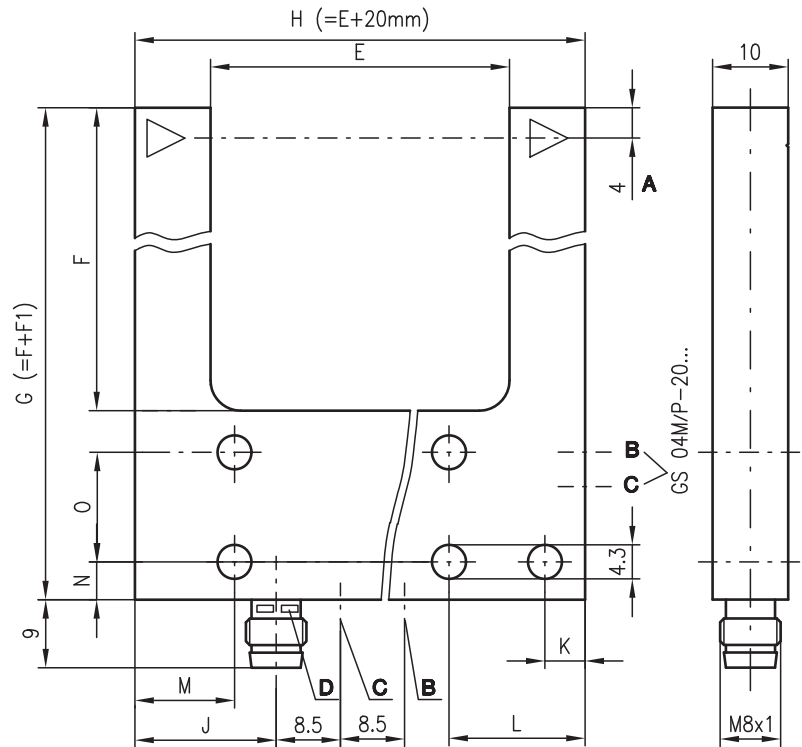

- A** Optical axis
- B** Sensitivity adjustment
- C** Light/dark switching
- D** Indicator diode

	E Mw	F Mt	F1	G	H	J	K	L	M	N	O
GS 04M/...-20...	20	24	25	49	40	6	4,5	12,5	-	4,5	-
GS 04M/...-30...	30	34	25	59	50	12	4,5	12,5	4,5	4,5	-
GS 04M/...-50...	50	54	25	79	70	12	4,5	12,5	4,5	4,5	-
GS 04M/...-80...	80	54	25	79	100	12	4,5	12,5	4,5	4,5	-
GS 04M/...-120...	120	54	30	84	140	37	-	18	22	5	20
GS 04M/...-220...	220	114	30	144	240	37	-	18	22	5	20

Electrical connection

GS 04 M/P

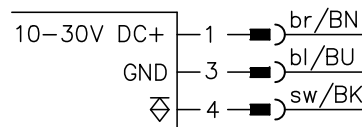

GS 04 M/N

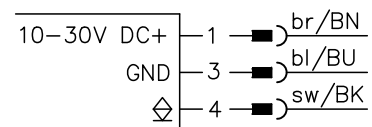

Accessories:

(available separately)

- M8 connectors (KD ...)
- Cable with M8 connector (K-D...)

We reserve the right to make changes • DS_GS04MPN_en_50110846.fm



Specifications

Optical data

Mouth width	20/30/50/80/120/220mm
Light source	LED (modulated light)
Wavelength	640nm red light

Timing

Switching frequency	1500Hz
Response time	0.33ms
Delay before start-up	≤ 100ms

Electrical data

Operating voltage U_B ^{1) 2)}	10 ... 30VDC (incl. residual ripple)
Residual ripple	≤ 15% of U_B
Open-circuit current	≤ 35mA
Switching output	PNP/NPN transistor output
Function characteristics	light/dark switching reversible
Signal voltage high/low	≥ ($U_B - 2V$) / ≤ 2V
Output current	200mA
Sensitivity	adjustable (potentiometer, adjustment range 0 ... 270°)

Indicators

Red LED	state of switching output
---------	---------------------------

Mechanical data

Housing	diecast zinc
Weight	see order guide
Optics cover	glass
Connection type	M8 connector, 3-pin

Environmental data

Ambient temp. (operation/storage)	-10°C ... +60°C / -20°C ... +70°C
Protective circuit ³⁾	1, 2
VDE safety class	III
Protection class	IP 67
Certifications	UL 508 ⁴⁾

1) Functional extra-low voltage with reliable disconnection or protective extra-low voltage (VDE 0100/T 410)

2) Observe the safety regulations and installation instructions regarding power supply and wiring

3) 1=polarity reversal protection, 2=short-circuit protection for all outputs

4) For UL applications: for use in class 2 circuits according to NEC only

Mouth width [mm]	Smallest detectable object [mm]	Reproducibility [mm]	Switching hysteresis [mm]
20	0,3	0,02	≤ 0,1
30	0,3	0,02	≤ 0,1
50	0,4	0,04	≤ 0,15
80	0,4	0,06	≤ 0,2
120	0,5	0,08	≤ 0,2
220	0,6	0,08	≤ 0,2

Order guide

Selection table		Order code →										
Equipment ↓		GS 04M/P-20-S8 Part No. 501 10792	GS 04M/P-30-S8 Part No. 501 10782	GS 04M/N-30-S8 Part No. 501 10791	GS 04M/P-50-S8 Part No. 501 10783	GS 04M/N-50-S8 Part No. 501 10789	GS 04M/P-80-S8 Part No. 501 10784	GS 04M/N-80-S8 Part No. 501 10790	GS 04M/P-120-S8 Part No. 501 10785	GS 04M/N-120-S8 Part No. 501 10787	GS 04M/P-220-S8 Part No. 501 10786	GS 04M/N-220-S8 Part No. 501 10788
Mouth width [mm]		20	30	30	50	50	80	80	120	120	220	220
Weight in g		28	36	36	54	54	77	77	118	118	220	220
Transistor output	PNP	●	●		●		●		●		●	
	NPN			●		●		●		●		●

Tables

Diagrams

Remarks

Operate in accordance with intended use!
⚠ This product is not a safety sensor and is not intended as personnel protection.
⚠ The product may only be put into operation by competent persons.
⚠ Only use the product in accordance with the intended use.